

ST80320



Miscelatore monocomando per lavello, bocca girevole, doccetta estraibile
2 getti in metallo con aggancio magnetico e aeratore 22x1.
Cartuccia ceramica, portata 12 l/min. Comando touch per funzione chiudi scarico
con tecnologia Guglielmi. Elettronica marchio CE. Flex di alimentazione softpex 3/8".
Fissaggio con sistema rapido. Compatibile con lavello ad una vasca.
Da abbinare con scarico 3" 1/2 automatico.

Single lever washbasin mixer, swivel spout, 2 jets metal extractable handshower
with magnetic connection and 22x1 aerator. Ceramic cartridge, 12 l/min flow rate.
Touch command for self-closing drainage function with Guglielmi technology.
CE branded electronic. 3/8" connection flexible hoses of softpex.
Fixing with rapid system. Compatible with one bowl sink.
To be combined with 3" 1/2 automatic drain.

CARATTERISTICHE FEATURES

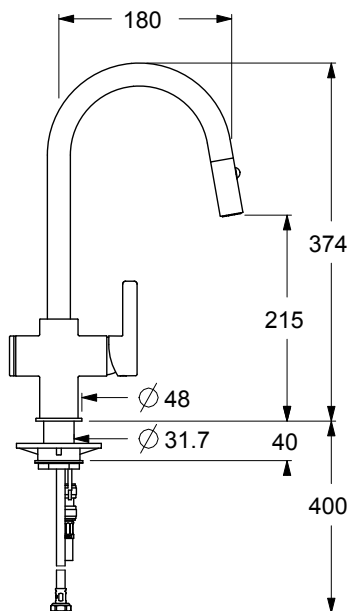

FORO UTILE HOLE WIDTH Ø35

CERTIFICAZIONI PRODOTTO PRODUCT APPROVALS

L'articolo può disporre di alcune di queste certificazioni.
The article may have some of these approvals.



IMBALLI E RICICLABILITÀ PACKAGING AND RECYCLING

SCATOLA BOX	VOLUME VOLUME	TARA TARE	PESO LORDO GROSS WEIGHT
11 x 36,5 x 78 cm	0,031 m ³	0,95 kg	4,75 kg
COLLO MC	VOLUME VOLUME	TARA TARE	N° SCATOLE PER COLLO N° BOXES FOR MC
38 x 80 x 40 cm	0,122 m ³	1,2 kg	3
PLASTICA PLASTIC	CARTA PAPER	PALLET PALLET	N° COLLI PER PALLET N° MC FOR PALLET
0,522 kg	1,35 kg	9,6 kg	9

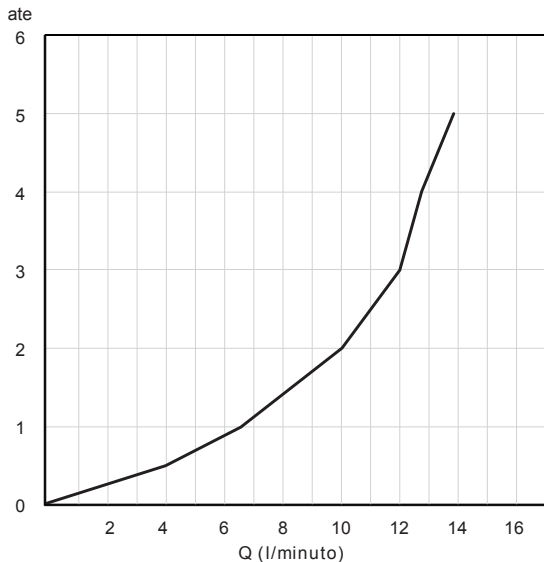

DIAGRAMMA DI PORTATA FLOW RATE DIAGRAM

Test eseguito secondo le norme europee EN 817 - EN 200.
Portata calcolata con l'impiego di aeratori certificati.

Test carried out according to the European standards EN 817 - EN 200.
Flow rate calculated by the application of certified aerators.

ate	1	2	3	4	5
Q (l/min)	6,5	10,0	12,0	12,8	13,8