

OS16110

Miscelatore monocomando per vasca-doccia incasso con deviatore automatico a 2 vie. Rosone Ø 170 in metallo. Cartuccia ceramica, portata 12 l/min. Completo di parte incasso.

Single lever mixer for built-in bath-shower with 2-way automatic diverter. Ø 170 metal plate. Ceramic cartridge, 12 l/min. Complete with built-in part.

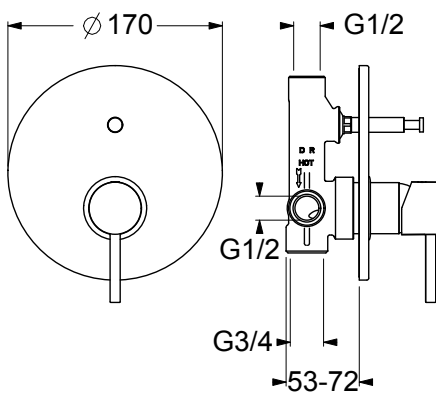

CERTIFICAZIONI PRODOTTO PRODUCT APPROVALS

L'articolo può disporre di alcune di queste certificazioni. The article may have some of these approvals.



IMBALLI E RICICLABILITÀ PACKAGING AND RECYCLING

SCATOLA BOX	VOLUME VOLUME	TARA TARE	PESO LORDO GROSS WEIGHT
7 x 18 x 21 cm	0,003 m ³	0,13 kg	1,44 kg
COLLO MC	VOLUME VOLUME	TARA TARE	N° SCATOLE PER COLLO N° BOXES FOR MC
26 x 40 x 40 cm	0,042 m ³	0,74 kg	12
PLASTICA PLASTIC	CARTA PAPER	PALLET PALLET	N° COLLI PER PALLET N° MC FOR PALLET
0,002 kg	0,192 kg	9 kg	24

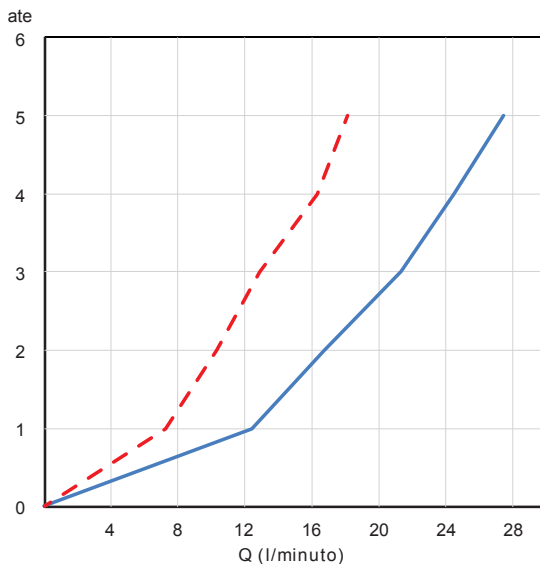

DIAGRAMMA DI PORTATA FLOW RATE DIAGRAM

Test eseguito secondo le norme europee EN 817 - EN 200. Portata calcolata con l'impiego di aeratori certificati.

Test carried out according to the European standards EN 817 - EN 200. Flow rate calculated by the application of certified aerators.

Doccia / Shower	-----				
ate	1	2	3	4	5
Q (l/min)	7,5	10,5	12,2	16,2	18,7
Vasca / Bath	—————				
ate	1	2	3	4	5
Q (l/min)	12,3	17,5	21,2	24,3	27,5