

AP62020

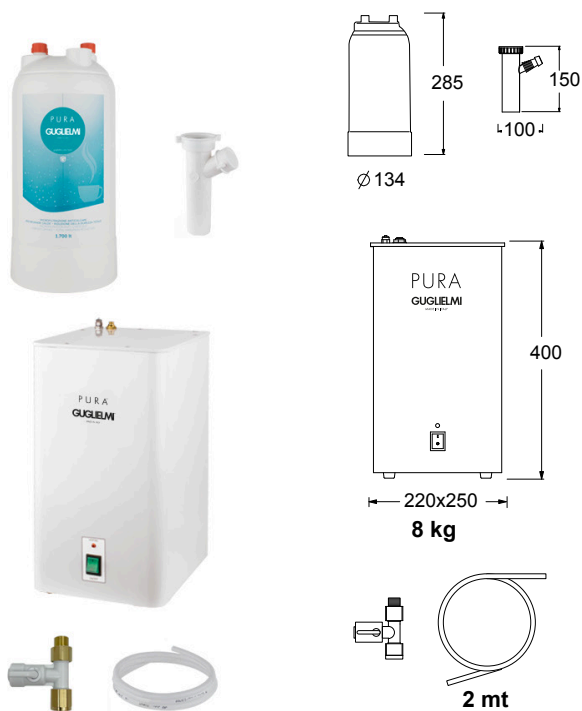
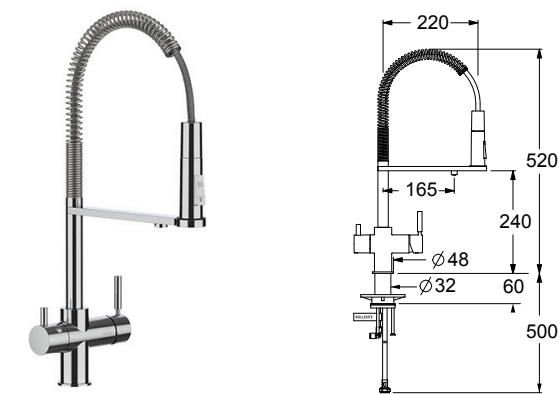

FORO UTILE HOLE WIDTH Ø35

Miscelatore monocomando per lavello semi-pro, bocca girevole, doccetta estraibile 2 getti in metallo con aggancio agevolato, cartuccia ceramica per acqua domestica portata 9 l/min. Vitone ceramico 65° in ecobrass con chiusura automatica per acqua bollente, portata 3 l/min. Blocco di sicurezza antiscottatura. Flex di alimentazione softpex 3/8", fissaggio a 3 viti, tubo LLDPE alimentare con aggancio rapido, valvola di intercettazione. Completo di sistema di microfiltrazione anticalcare e boiler con tecnologia Guglielmi. Elettronica marchio CE.

Semi-pro single lever sink mixer, swivel spout, 2 jets metal pull-out handshower with easy connection, ceramic cartridge for domestic water 9 l/min flow rate. 65° ceramic ecobrass valve with automatic locking for boiling water, 3 l/min flow rate. Safety lock preventing from burn. 3/8" connection flexible hoses of softpex, assembling support with 3 screws, LLDPE food pipe with quick connection, interception valve. Complete with microfiltration anti-limescale system and boiler with Guglielmi technology. CE branded electronic.

CARATTERISTICHE FEATURES



CERTIFICAZIONI PRODOTTO PRODUCT APPROVALS

L'articolo può disporre di alcune di queste certificazioni. The article may have some of these approvals.



IMBALLI E RICICLABILITÀ PACKAGING AND RECYCLING

SCATOLA BOX	VOLUME VOLUME	TARA TARE	PESO LORDO GROSS WEIGHT
7 x 35 x 79 cm	0,019 m ³	1,6 kg	15,75 kg
COLLO MC	VOLUME VOLUME	TARA TARE	N° SCATOLE PER COLLO N° BOXES FOR MC
51 x 81 x 47 cm	0,194 m ³	1,83 kg	1
PLASTICA PLASTIC	CARTA PAPER	PALLET PALLET	N° COLLI PER PALLET N° MC FOR PALLET
0,332 kg	4,08 kg	9,6 kg	6

DIAGRAMMA DI PORTATA FLOW RATE DIAGRAM

Test eseguito secondo le norme europee EN 817 - EN 200. Portata calcolata con l'impiego di aeratori certificati.

Test carried out according to the European standards EN 817 - EN 200. Flow rate calculated by the application of certified aerators.

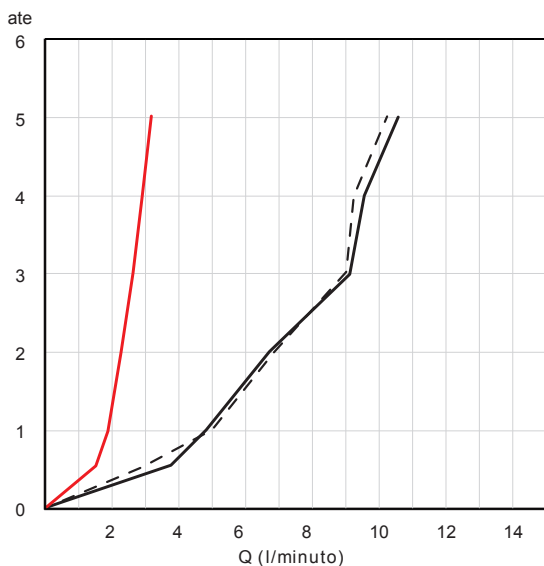

ACQUA DOMESTICA DOMESTIC WATER						ACQUA MICROFILTRATA MICROFILTERED WATER					
Acqua miscelata Mixed water						Acqua bollente Boiling water					
ate	1	2	3	4	5	ate	1	2	3	4	5
Q (l/min)	4,8	6,8	9,1	9,5	10,6	Q (l/min)	1,9	2,2	2,8	3,5	4,1
Doccetta spray Spray shower						Doccetta spray Spray shower					
ate	1	2	3	4	5	ate	1	2	3	4	5
Q (l/min)	5,0	6,9	9,0	9,2	10,2	Q (l/min)	5,0	6,9	9,0	9,2	10,2